

		<small>UNLESS OTHERWISE SPECIFIED, STANDARD PROCESSING CHECKS APPLY. TOLERANCES: LINEAR DIM'S MORE THAN 11.8 INCH: +0/-0.04 LINEAR DIM'S LESS THAN 11.8 INCH: +0/-0.02 ANGULAR DIMENSIONS: ±0.02° HOLE PUNCHING: ±0.02</small>		<h1>Burmon-ICFWL</h1>	
CUSTOMER APPROVED:	DATE:	NAME	DATE		
-	-	DRAWN	-		
		CHK'D	-		
MATERIAL SPEC:		MATERIAL:		TITLE:	
-		-		-	
		WEIGHT: -grams		PART / DRAWING NO.: -	
				A3	
				REVISION:	

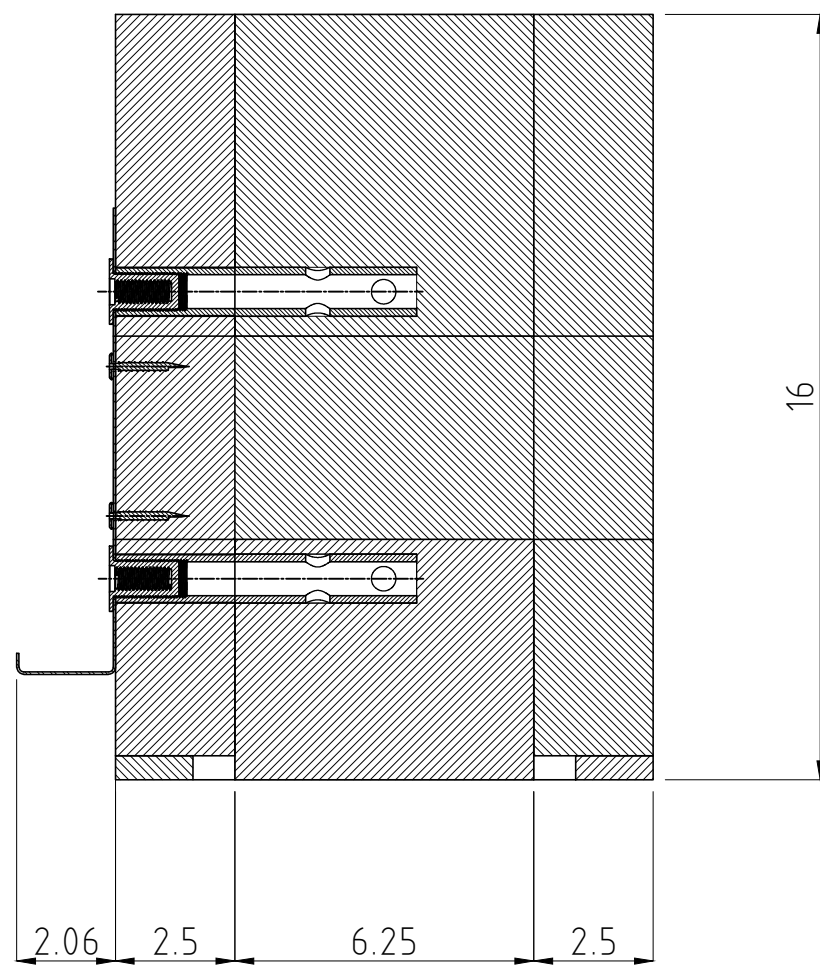

SECTION B-B

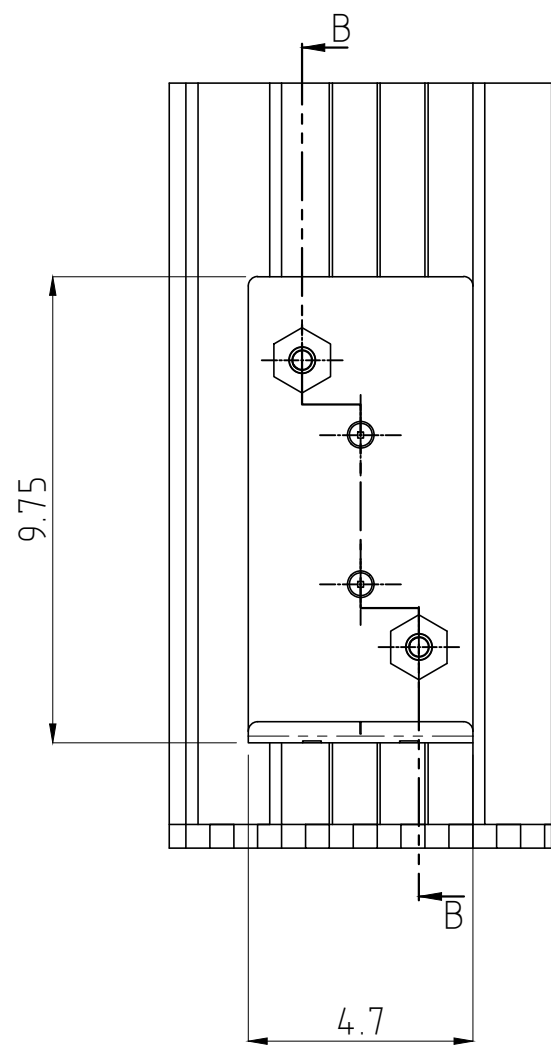
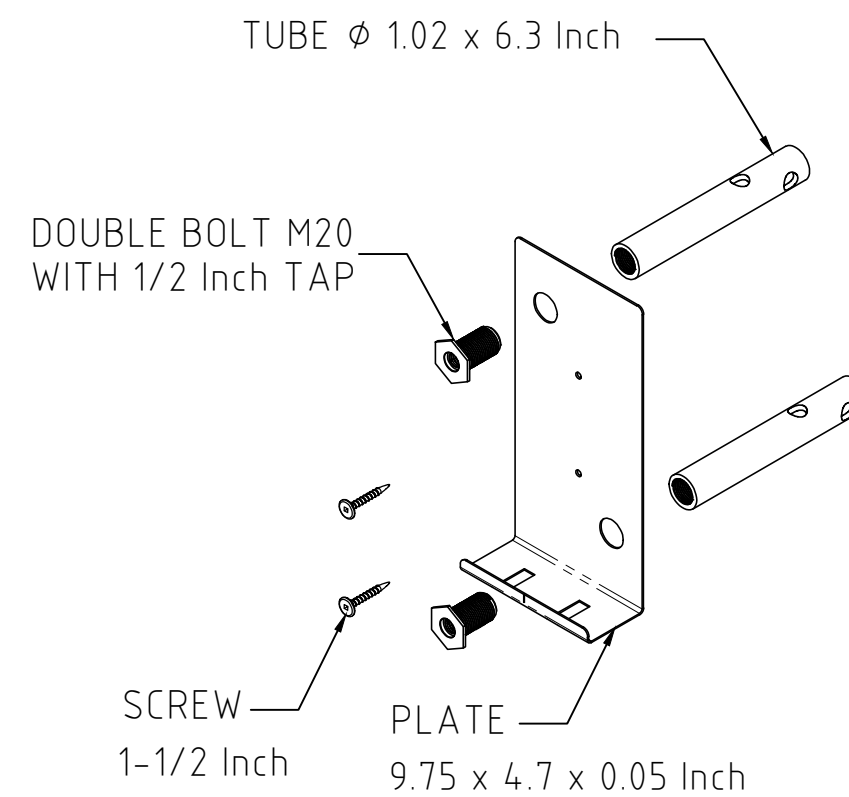

		<small>UNLESS OTHERWISE SPECIFIED, STANDARD PROCESSING CHECKS APPLY.</small> <small>TOLERANCES:</small> <small>LINEAR DIM'S MORE THAN 11.8 INCH: +0/-0.04</small> <small>LINEAR DIM'S LESS THAN 11.8 INCH: +0/-0.02</small> <small>ANGULAR DIMENSIONS: ±0.02°</small> <small>HOLE PUNCHING: ±0.02</small>		<h2 style="text-align: center;">Burmon-ICFWL connected to ICF Wall</h2>	
		CUSTOMER APPROVED:	DATE:		
MATERIAL SPEC:		MATERIAL:		TITLE:	
		WEIGHT: -grams		PART / DRAWING NO.:	
				A3	
				REVISION:	

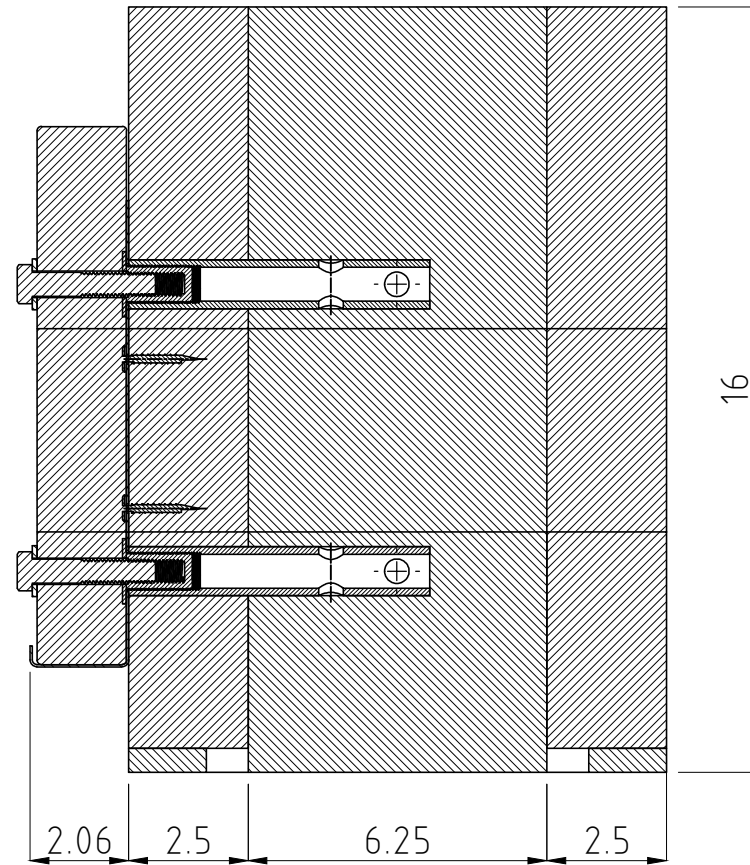
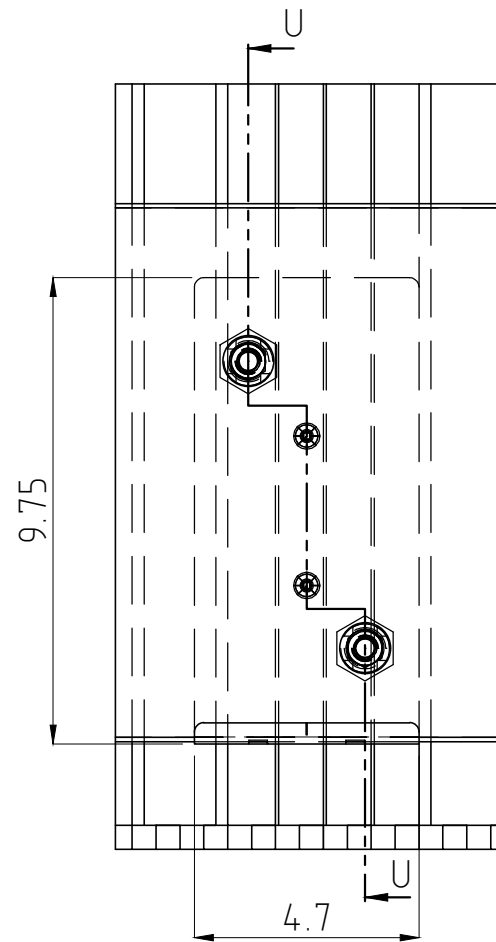

SECTION U-U

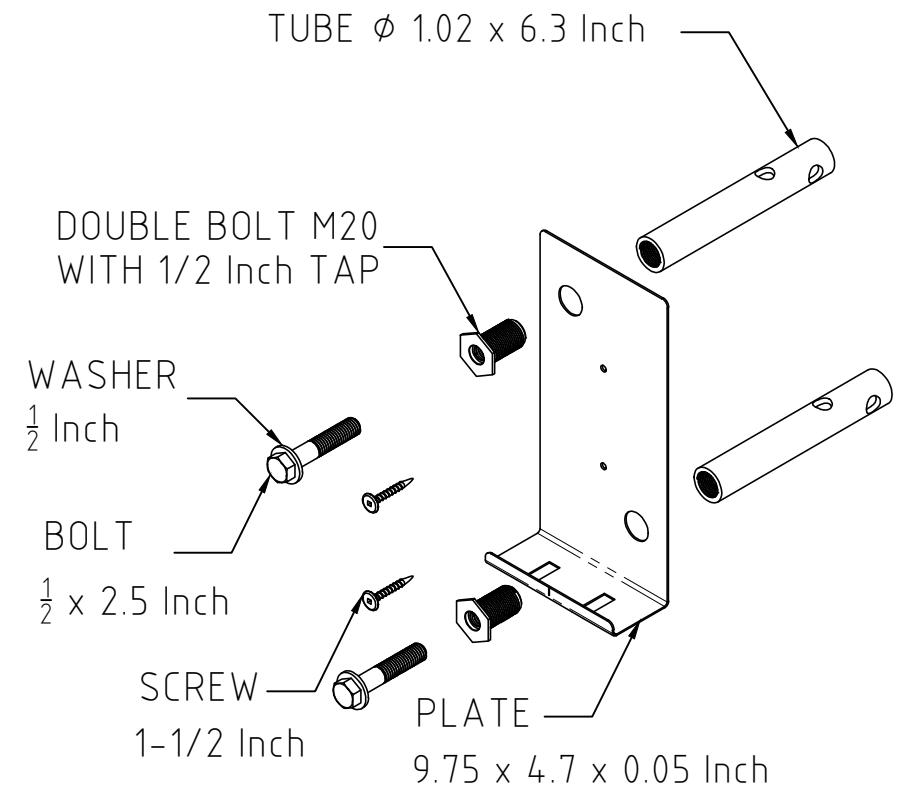

		<small>UNLESS OTHERWISE SPECIFIED, STANDARD PROCESSING CHECKS APPLY.</small> <small>TOLERANCES:</small> <small>LINEAR DIM'S MORE THAN 11.8 INCH: +0/-0.04</small> <small>LINEAR DIM'S LESS THAN 11.8 INCH: +0/-0.02</small> <small>ANGULAR DIMENSIONS: ±0.02°</small> <small>HOLE PUNCHING: ±0.02</small>		<h2 style="text-align: center;">Burmon-ICFWL</h2> <h3 style="text-align: center;">connected to Wood Ledger</h3>	
		CUSTOMER APPROVED:	DATE:		
MATERIAL SPEC:		MATERIAL:		TITLE:	
		WEIGHT: -grams		PART / DRAWING NO.:	
				A3	
				REVISION:	